

“Solutions within Reach”

We provide consultancy services as well as design, engineering and manufacturing on a wide range of architectural hardware and extrusion products.

SLIDING WINDOW (SW70B)



SW70B Sliding Window (Series 2)

Typical Assembly Details:

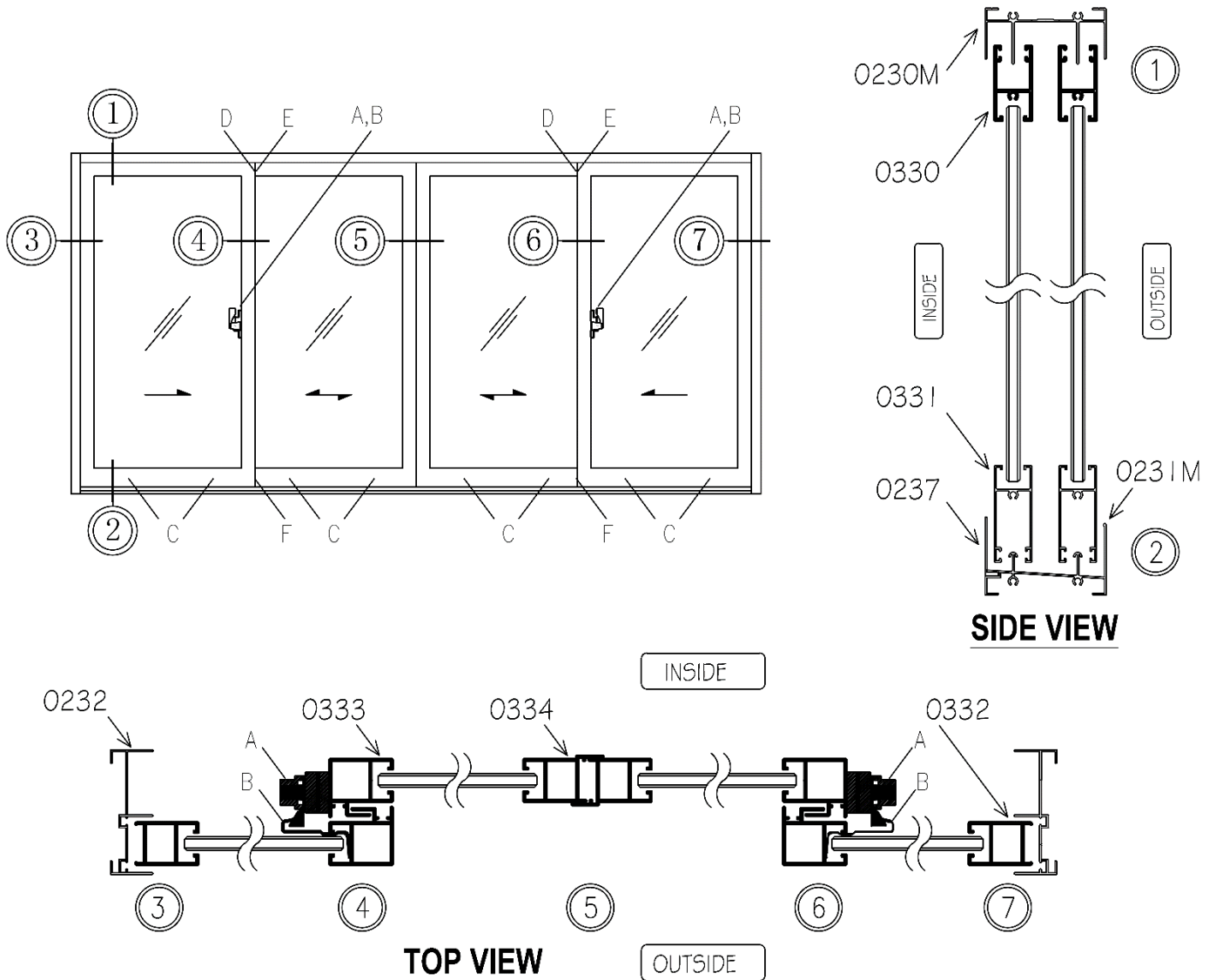

Hardware Accessories:



SW70B Sliding Window (Series 2)

Sectional Details:

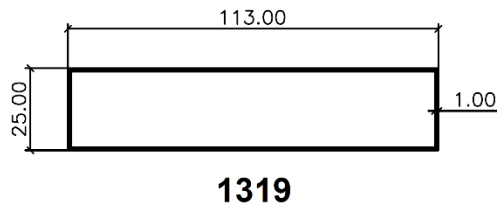
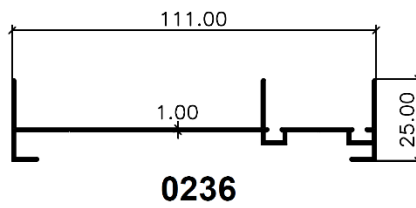
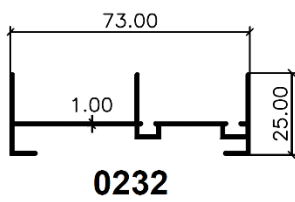
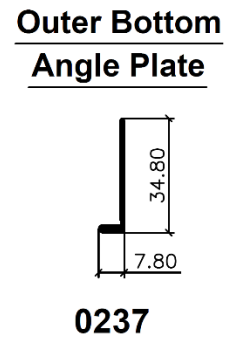
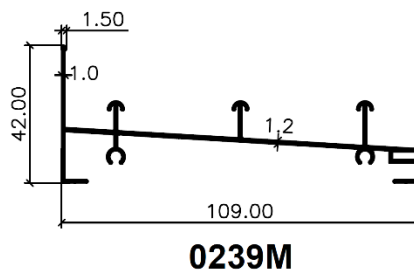
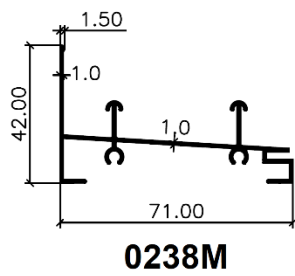
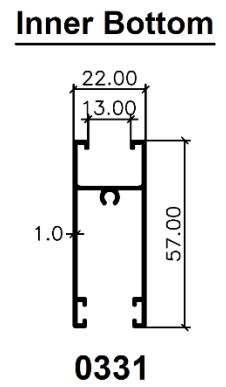
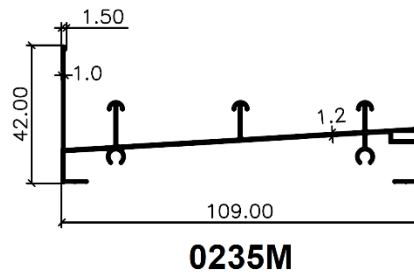
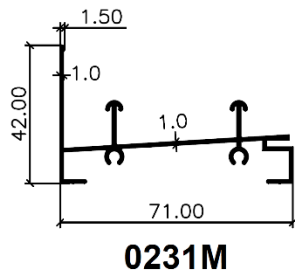
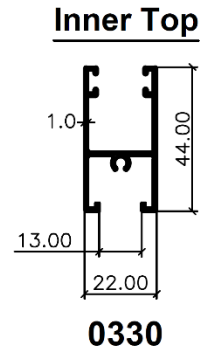
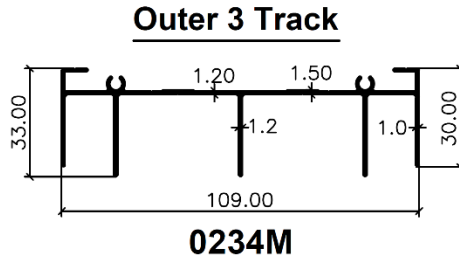
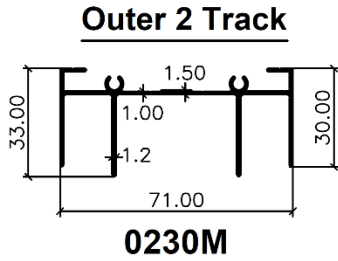

Inner Side

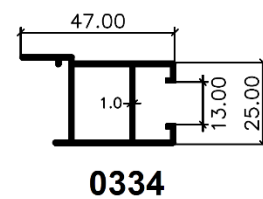
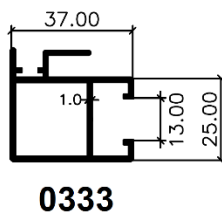
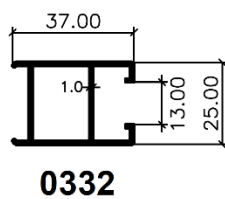



SINCE 1978

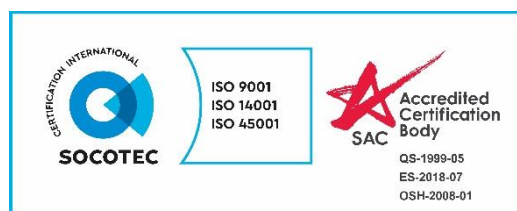

HQ Office:

12 Joo Koon Crescent,

Singapore 629013

Tel: 6745 0204

Fax: 6748 1741

Email: sales@alphametals.com.sg

<http://www.alphametals.com.sg>

Branch:

Block 4023 #01-343/345/347,

Ang Mo Kio Ind. Park 1 Singapore 569634

Tel: 6455 5576

Fax: 6455 5587