

“Solutions within Reach”

We provide consultancy services as well as design, engineering and manufacturing on a wide range of architectural hardware and extrusion products.

BI-FOLD DOOR (H-SERIES)



Bi-Fold Door (H Series)

Typical Assembly Details:

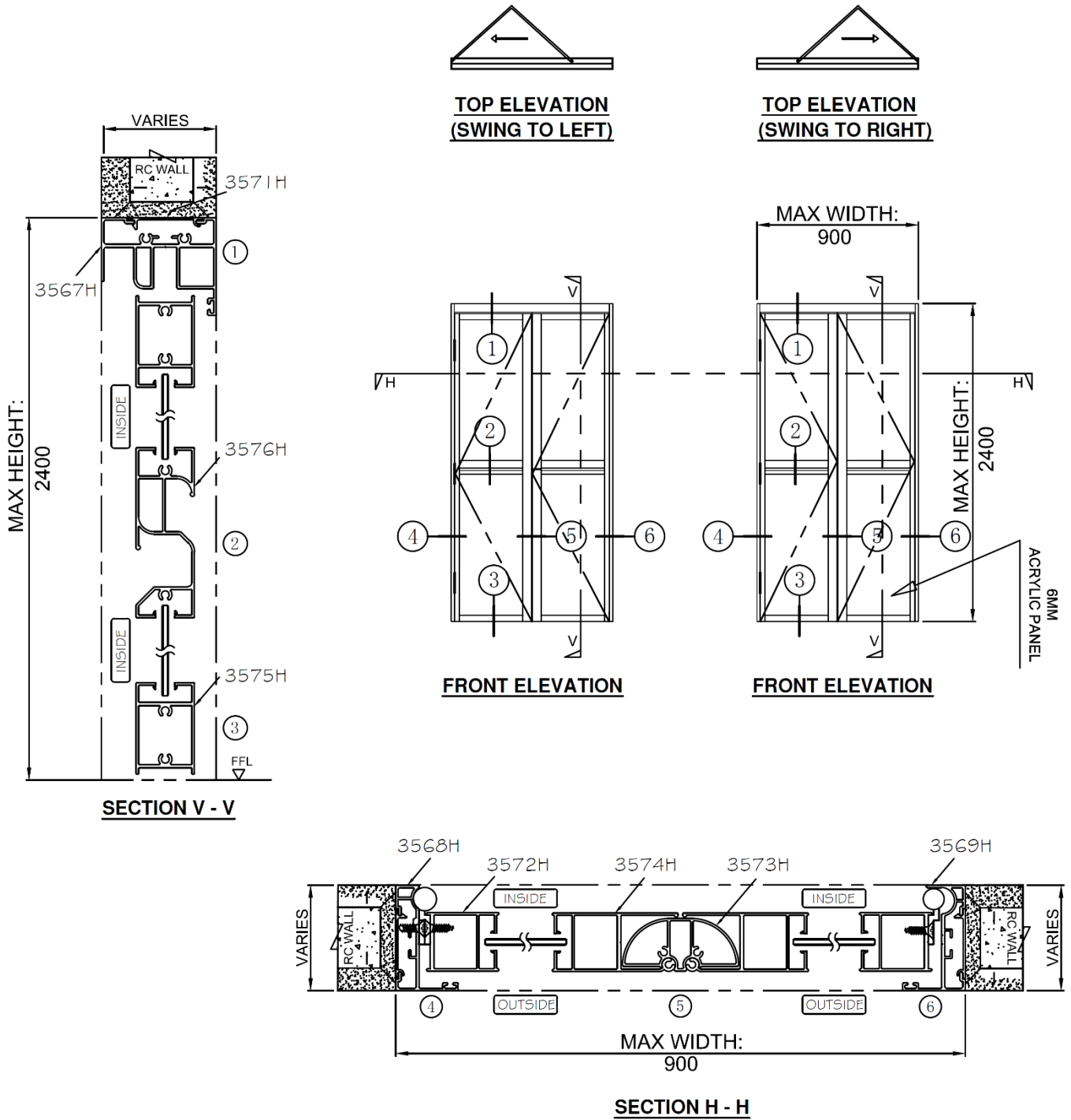

Bi-Fold Door (H Series)

Sectional Details:

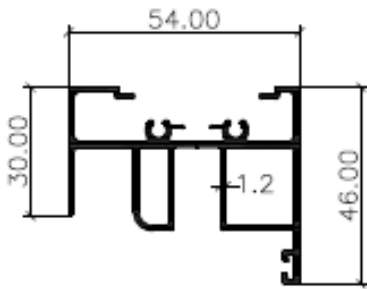

3567H

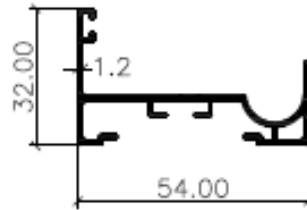

3569H

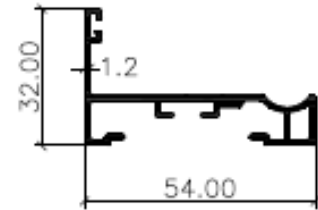

3568H

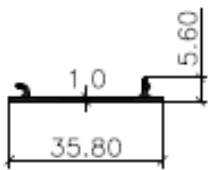

3571H

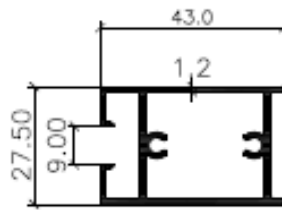

3575H

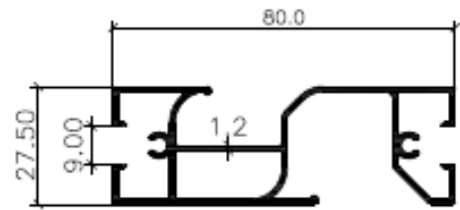

3576H

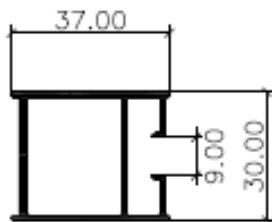

3572H

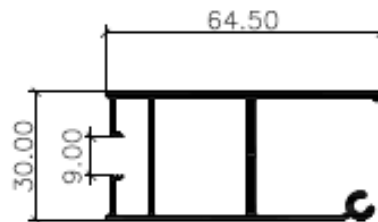

3574H

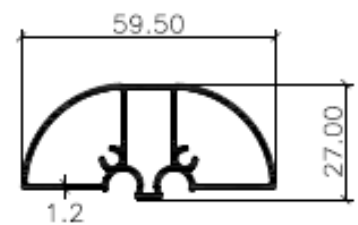

3573H

Bi-Fold Door (H Series)

Hardware Fittings:

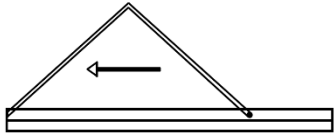

TOP ELEVATION
(SWING TO LEFT)

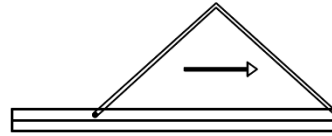

TOP ELEVATION
(SWING TO RIGHT)

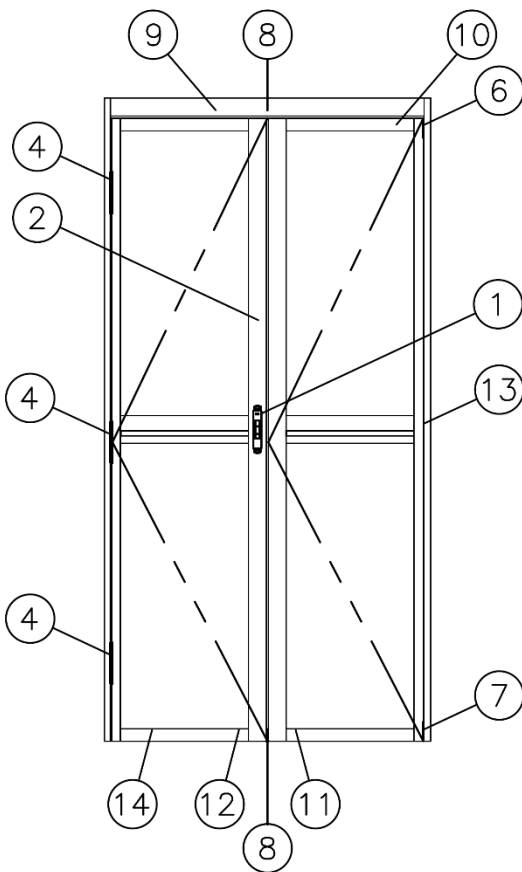

FRONT ELEVATION

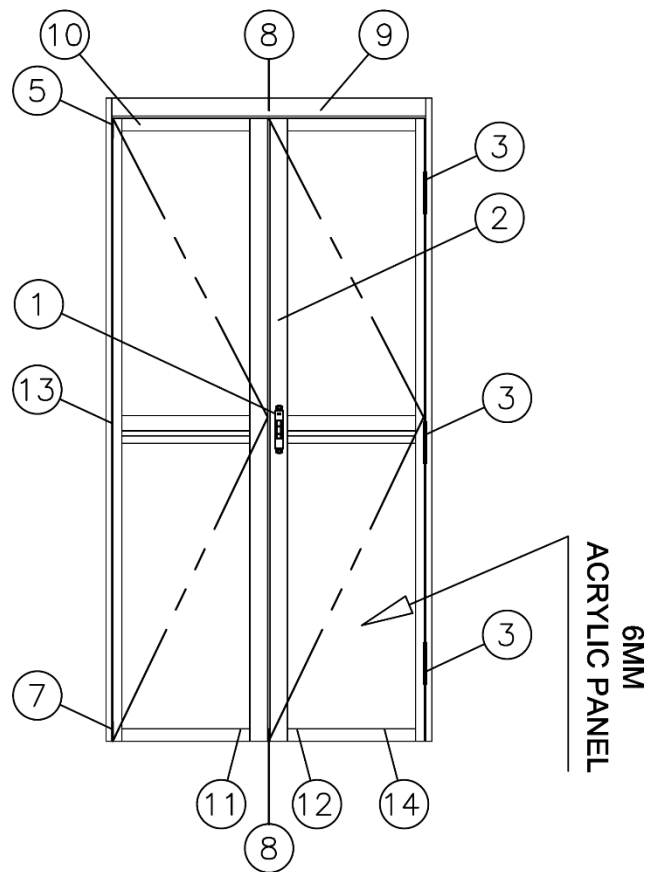

FRONT ELEVATION

Bi-Fold Door (H Series)

Hardware Accessories:



1) 4542M-HL



2) 5099H-D10-950



3) 7120A



4) 7120B



5) 7121A



6) 7121B



7) 7122



8) 7123



9) 4468-BKC



10) 4469-BKC



11) 4470-BKC



12) 4471-BKC



13) 4404-3/8



14) 4472-BKC

NOTES



A series of horizontal dashed lines providing a template for writing notes.

NOTES



A series of horizontal dashed lines providing a template for writing notes.



SINCE 1978

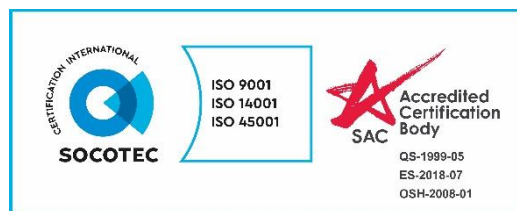

HQ Office:

12 Joo Koon Crescent,

Singapore 629013

Tel: 6745 0204

Fax: 6748 1741

Email: sales@alphametals.com.sg

<http://www.alphametals.com.sg>

Branch:

Block 4023 #01-343/345/347,

Ang Mo Kio Ind. Park 1 Singapore 569634

Tel: 6455 5576

Fax: 6455 5587